

Information Technology Advisory Committee (ITAC)

Public Business Meeting
June 5, 2020 Videoconference

Hon. Sheila F. Hanson
Chair, Information Technology Advisory Committee

Administrative Matters

I. Open Meeting

- Call to Order, Roll Call

II. Public Comment



REPORT

Item 1. Chair Report

Hon. Sheila F. Hanson

Chair, Information Technology Advisory Committee

There are no slides for this item.

REPORT

Item 2. Innovation Grant Showcase: Remote Video Appearances

Mr. Jake Chatters

Court Executive Officer, Superior Court of
Placer County

Proceed to the next slide for this item.

Integrated Remote Appearance System



Jake Chatters,
Court Executive Officer
Superior Court of California,
County of Placer

June 5, 2020

Overview

1. Project Goal
2. Policy and Design Considerations
3. System Architecture
4. Process Flow
5. Demonstration
6. Lessons Learned
7. Questions

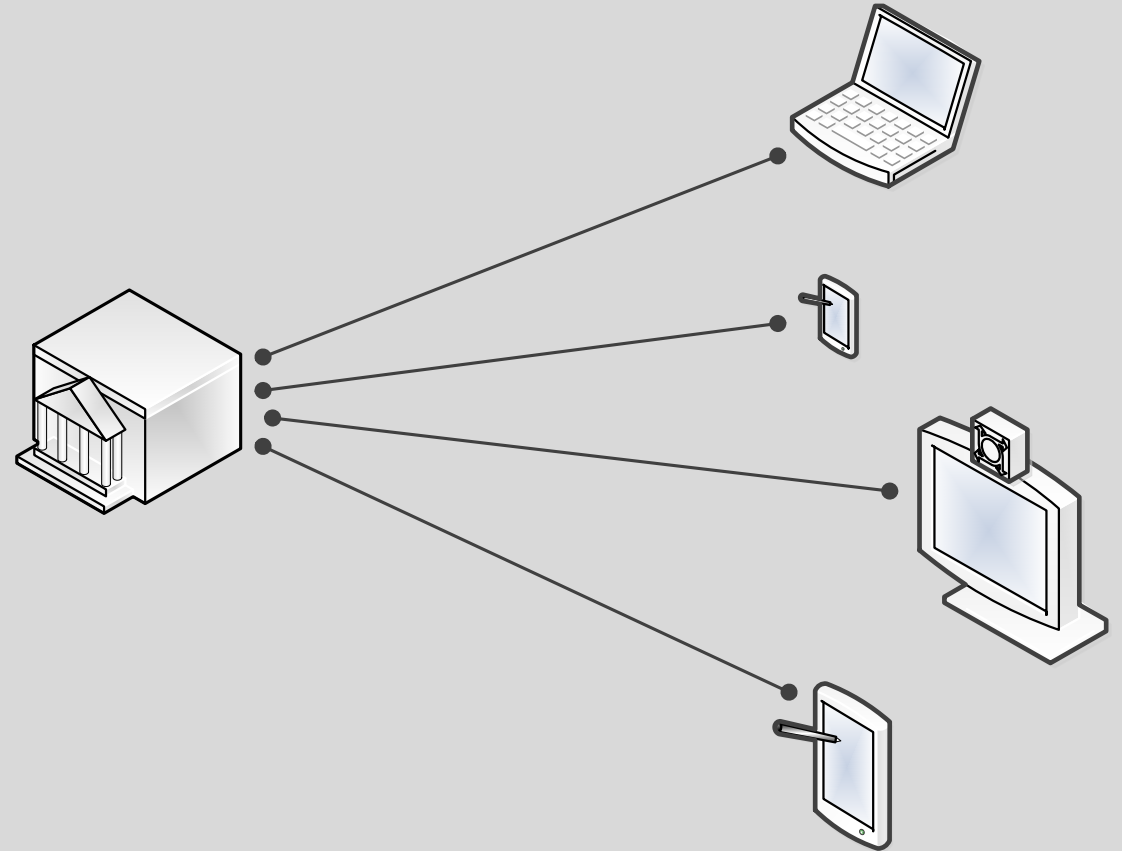

Project Goal

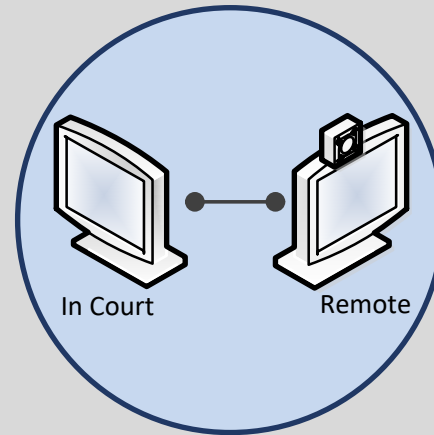

Create an end-to-end solution that replicates the court experience as authentically as possible, provides heavy court control, and minimizes the impact on court users and staff.



Caveat – COVID 19



INFORMATION REGARDING CORONAVIRUS

COVID-19 - Current Court Services Notice (Detailed) - Updated May 7, 2020

COVID-19 - Infographic of Current Court Services - Updated May 29, 2020

COVID-19 - Court Service Plan for Criminal Law, as of May 29, 2020

COVID-19 - Court Service Plan for Civil Law, as of May 29, 2020

COVID-19 - Court Service Plan for Family Law, as of May 29, 2020

COVID-19 Webpage (Includes All Public Notices, Orders and FAQs)

This design and policy decisions for the Placer Superior Court remote appearance solution was developed pre-COVID 19.



Policy Implications Due Process

What if the party objects to the video appearance?

What instructions do we provide?

When and how are Stipulations to Commissioner or Pro Tem sent to the party?

Placer County Superior Court now offers video appearances for Small Claims and Unlawful Detainer cases. This is an optional service wherein you and/or the other party appear from a remote location using any device capable of capturing and displaying a clear audio and visual stream at a sufficient internet speed.

Use this packet if you are interested in requesting a video appearance **in your next hearing**.

Contents

IF YOU WISH TO APPEAR BY VIDEO FOR YOUR NEXT HEARING...
 IF YOU ARE NOTIFIED THAT THE OTHER PARTY INTENDS TO APPEAR BY VIDEO FOR YOUR NEXT HEARING...
 SCHEDULING YOUR VIDEO APPEARANCE
 Two to Three Days Before Your Hearing
 On the Day of Your Hearing
 Reminders
 SUBMITTING EVIDENCE FOR VIDEO APPEARANCES
 Uploading Evidence
 Viewing Evidence

Revision Date: 3/2/20

SUPERIOR COURT OF CALIFORNIA COUNTY OF PLACER

This is a confirmation for **JAN Chatters from Placer Superior Court**. You have been scheduled for the remote appearance(s) shown below.

Payment Confirmation
 Total Amount Paid: \$0.00
 Confirmation Number: 51899902266
 For payment issue: gst@scsdc.org or 916-808-6000

How to Join Your Remote Event
 On the date & time of your event, connect:
 By VIDEO: Use your video capable device. Click on the **Conference ID** or video link above (or paste the link into your browser).
 You will need the **Conference ID** and **Conference PIN** shown below.

Remote Appearances Scheduled

| Event Date & Time | Case Number | Event Description | Amount Paid | Conference ID* | Conference PIN | Event Instructions |
|-------------------|-------------|-------------------|-------------|----------------|----------------|-------------------------------|
| 9/6/2019 9:00 AM | DK42 | Trust#242 | Tot 123 | 1273816 | 9813 | Video Hearing |

* Conference ID: <https://meetings.applacemo.com/conference/join?autoJoinPasscode=19729056&autoJoinPage=5023>



Design Considerations Experience

How is the calendar managed?

The screenshot shows the ConferenceManager interface. On the left is a 'Dial Out' form with fields for Name (Self-Help CompanionWeb), Phone, and Extension. It includes options for Audio and Video, a 'Dial Now' button, and a 'Skip Host PIN' checkbox. On the right is the 'CONFERENCE ID: 67000' control panel, which shows 'There are [6] participants.' and a 'Show who's talking' checkbox. Below this are buttons for 'mute all', 'hold all', and 'disconnect all'. A list of participants is shown with columns for 'private', 'mute', 'hold', and 'disconnect' buttons. The 'mute' button for the participant '10-172019-Laila Vranecu' is highlighted in orange.

Court Staff Can manage callers (*hold, mute, end call*)

How do we handle disruptive behavior?

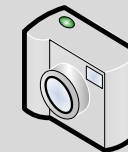

Video Appearances System Architecture

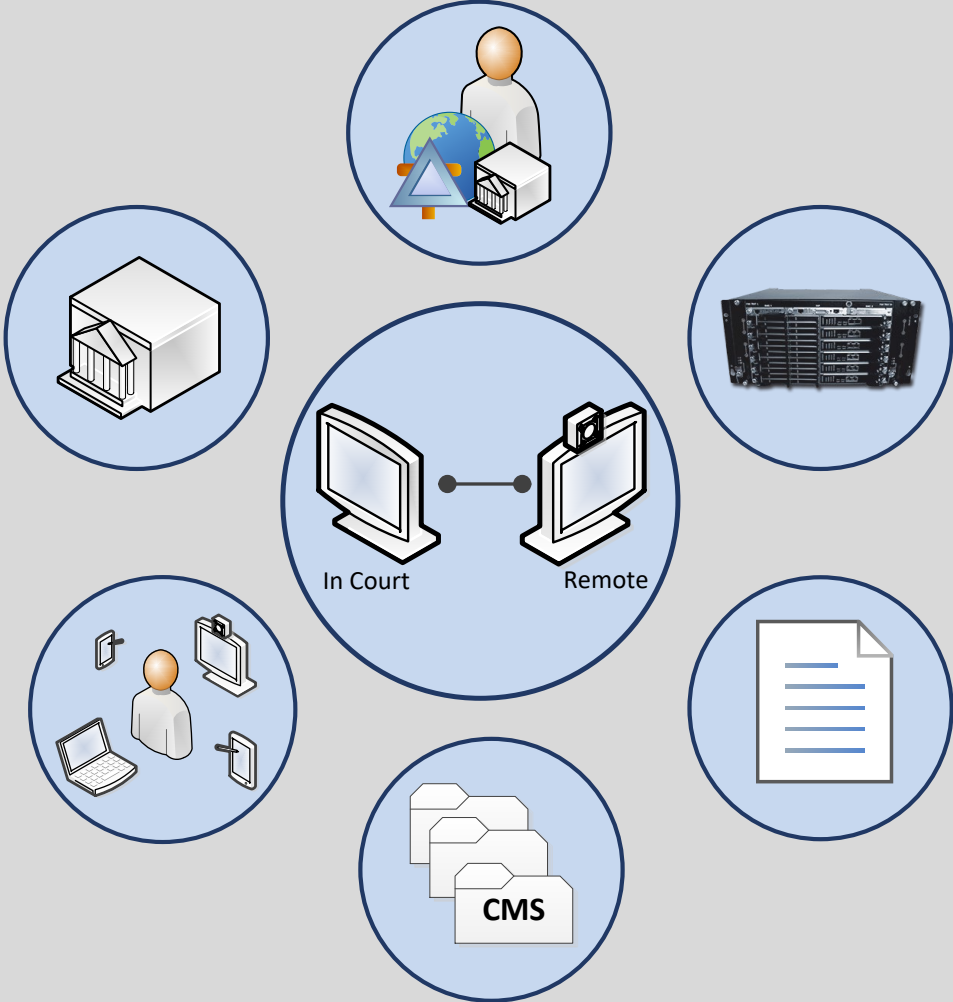



Single Point of Entry and Control for Courtroom Proceedings

Evergreen Cypress MCU

- Connects external connections to courtroom
- 86 Concurrent Video Connections
- Open-source technology (WebRTC)
- Allows Video Call with minimal bandwidth
- Uses SIP and the primary protocol
- Requires a Turn Server

CO-Turn Harden Application

Court selected the harden application out of concerns of vulnerabilities with the software.

Computnetix Companion Server

Allows the MCU to support Computer to Computer Connections with Screen sharing capabilities.

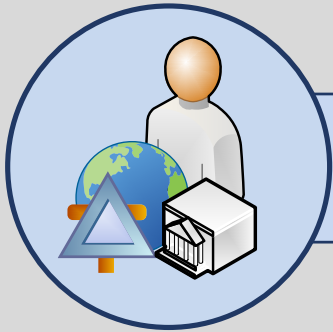

Minimize Number of Systems and Controls Necessary for Courtroom Staff

VCourt: ATI

- Leveraged existing telephonic vendor and technology
- Enhanced system to support video conferences
- Subsequently enhanced system to support evidence sharing



SUPERIOR COURT OF CALIFORNIA COUNTY OF PLACER

VCourt™ Remote Appearances with VCourt™ Evidence

Welcome to Placer VCourt. Select an option below to continue.

Note: Sign In is required to schedule video appearances or participate in Evidence Sharing.

Schedule a remote telephone or video appearance for a case with the Court.

Schedule

Access online evidence sharing for uploading and managing documents for your case.

Evidence

Cancel a previously scheduled remote telephone or video appearance.

Cancel

VCourt Landing Page

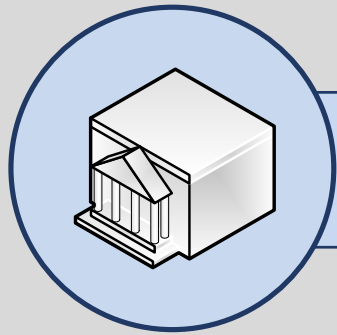

Integrated with the Court's various Courtroom Audio Video Systems

Each of the Courts five locations have different Audio Video equipment and control systems, with varying levels of complexities:

- The less advanced has a Cisco Codec and a single camera and monitor.
- The most complex system uses an AMX touchscreen to control over 75 different Audio Video components.



System had to be able to operate in all of the courtrooms, and be controlled by the Courtroom Audio Video System, therefore could not have a emailed link that started the conference.

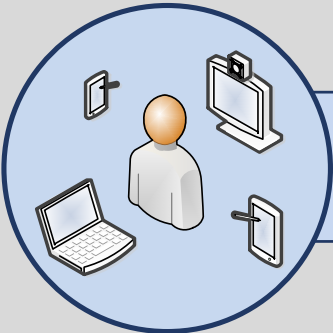
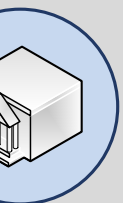
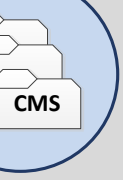

Users have to ability to connect from anywhere on any device

State Hospital
Uses a direct IP Address

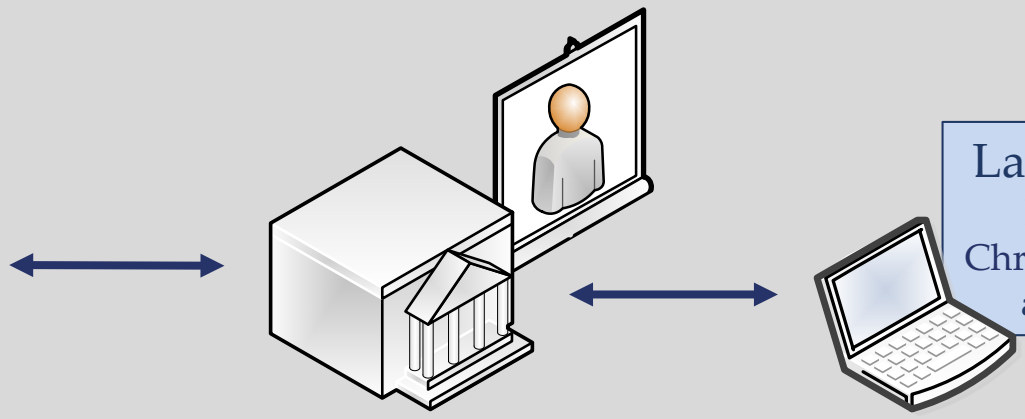

Laptop or Desktop Computer
Microsoft, Apple, Dell, etc. with
Chrome version 54 or above, a webcam
and microphone that is on Wi-Fi

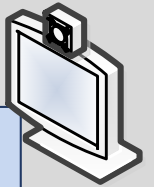

iPhone or iPad
Safari version 12 or above that
is wireless or on a network



Android Phone or Tablet
Chrome version 57 or above that is
wireless or on a network



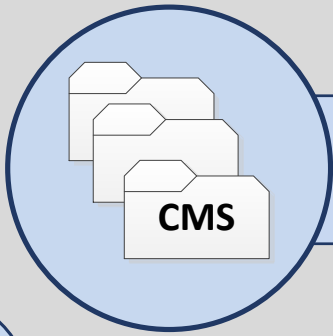

Integrated with Court Case Management System and Online Appointment System

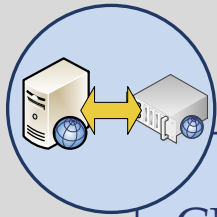

CMS informs video system of eligible hearing types based on event coding



Court users, staff, or batch schedule video appearance takes place on VCourt

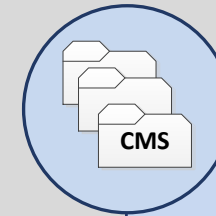

CMS is updated

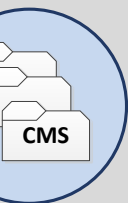

Evidence Sharing Solution that Replicates the In-person Process

VCourt Platform leveraged to allow for Evidence Sharing



Based on Microsoft SharePoint that is located on premise



Certain document types are uploaded by parties online or at the court

- Parties login using ICC Azure Identity Manager
- Uploaded files are scanned six times with four different anti-virus software applications.



Clerk is able to login and mark or admit evidence uploaded by the parties

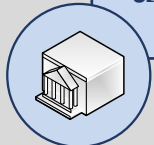

Videos & Live Demonstration

Scheduling Remote
Appearance

Evidence: Party's View

Evidence: Clerk's View



Planned Pilot Implementation

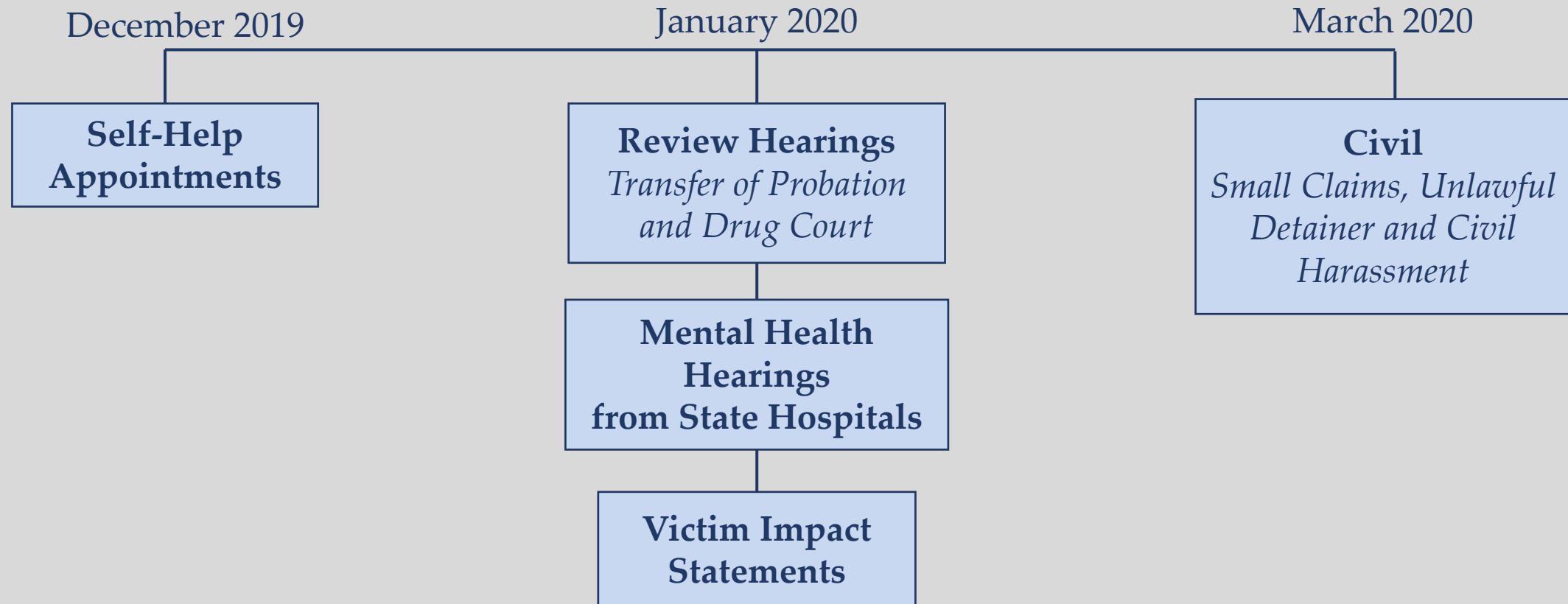

COVID-19: Expansion of Hearing Types

Due to the modifications to court operations, certain hearing types were not being held (ex: Unlawful Detainer and Small Claims). This prevented piloting the evidence solution, however, eligible hearing types expanded to:

Criminal

- Arraignments
- Out-of-Custody Pre-Trial Hearings
- Mental Health
- Drug Court
- Transfer of Probation
- Victim Impact Statements

Family Law

- Adoptions
- Restraining Orders
- Termination of Parental Rights
- Freedom of Custody & Control
- Mandatory Settlement Conferences
- Evidentiary Hearings & Long Cause Trials
- Default/Court Judgement

Civil

- Temporary Guardianship & Conservatorship
- Restraining Orders
- Firearms Petitions
- Unlawful Detainer
- Small Claims
- Evidentiary Hearings & Trials
- Mandatory Settlement Conferences
- Habeas Corpus



COVID-19: Expansion of Hearing Types

- Automated daily conferences for each criminal courtroom for:
 - DA
 - PD
 - Conflict Firm
 - Probation
- By request for private defense counsel and defendant for all pretrial hearings, except preliminary hearings
- Video arraignments implemented June 2.

Criminal



Lessons Learned

| Hearing Type | Number (Video) |
|------------------------|----------------|
| Criminal | 99* |
| Civil | 3 |
| Mental Health | 13 |
| Family Law | 26 |
| Juvenile | 4 |
| Self-Help Appointments | 133 |
| Total | 278 |

1. Communication with remote party.
 - Anticipated summer 2020.
2. WiFi versus Cellular.
3. Web RTC versus App-based structure.
4. Cannot create breakout rooms.
 - Adding by end-June 2020.
5. On premises instead of cloud.
6. eSignatures are possible.

* Private attorneys and defendants only.
Does not include participation by DA,
Probation, and Public Defender.



Costs

- Innovations Grant ~\$830,000
 - Software enhancements.
 - Courtroom A/V improvements.
 - SharePoint.
 - Video appearance hardware.
 - Staff support on the project.
- Almost three years invested so far
- Potential ongoing staff costs
 - Usage Monitor, System Operator, User Support
- For next adopters:
 - BCP funding
 - Provider to offer hosted solution.

| Remote Appearance Costs (Ongoing) | |
|--------------------------------------|------------------|
| ATI Compunetix Support | \$29,000 |
| Comunetix Licensing | \$40,000 |
| ATI IWR/IVR | \$17,500 |
| BlueJeans (3 accounts) | \$720 |
| ATI Contingency (15% price increase) | \$12,975 |
| vCourt Annual Licensing | \$101,000 |
| Usage Monitor (0.5 FTE) | \$42,000 |
| System Operator (0.5 FTE) | \$42,000 |
| User Support (1.0 FTE) | \$84,000 |



Questions?



REPORT

Item 3. Workstream Spotlight: Disaster Recovery Initial Pilot and Knowledge Sharing

Mr. Paras Gupta
Workstream Executive Sponsor

Proceed to the next slide for this item.

ITAC: DR Phase II Workstream

IG: Cloud-Based Disaster Recovery



ITAC Report: June 5, 2020

Brian Damschen, Rick DeNoyer, Paras Gupta



Superior Court of California
County of Monterey

DR2C : Goals & Benefits



Implement emerging DR cloud technologies

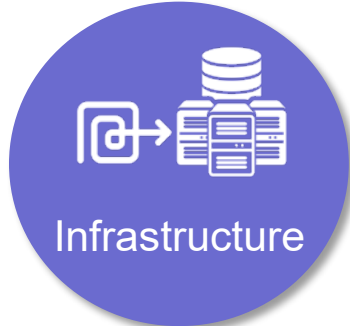

Simplify DR and reduce Infrastructure footprint



Drive solutions with Consortia led effort



Gain efficiencies with local resources



Hold Knowledge sessions for solution adoption



Reduce Interruption to court services



DR2C Team



ITAC **Workstream**

Marin, Los Angeles, 2DCA, Mendocino, Orange,
Santa Clara, Santa Barbara, Placer, Monterey, Judicial
Council



Monterey

Monterey Court IT Team Members



Project Manager
Brian Damschen



Vendor Partners



Gartner Microsoft EQUINIX :infiniti

DR2C Approach

Phase II: Monterey DR Pilot

Discovery & Analysis

Solution Design

Pilot CMS

Implement P1 Services

 Vendor Engagement

- Assessment & Recommendations
- Tools & Templates

Independent Research 

- Existing Infrastructure
- Peers
- Web
- Gartner Inquiry
- Demo Solutions
- Build out Azure footprint
- Pilot Solution
- Workstream Members



Priority Services



- Case Management System



- Portal - Online case records & services
- Public Website
- Jury System
- Criminal E-filing Services



- Telephone System



7. Disaster Recovery (DR) Initial Pilot and Knowledge Sharing

★ Highlight:

| Key Objectives | Status | Description |
|---|-------------|--|
| Identify core team (sponsor and leads); form group membership; hold kickoff meeting(s). | Completed | Roster approved on February 28, 2019. Workstream kickoff held on March 29, 2019. Biweekly meetings scheduled. |
| Establish a cloud DR master agreement with a short list of cloud service providers for judicial branch entities/courts to leverage. | Completed | Agreement completed November 20, 2018, with Infiniti Consulting, Inc. |
| (a) Recommend a list of critical technology services that make business sense for cloud-based recovery adoption. | In Progress | Infrastructure and systems that provide essential court services categorized as Priority (PI) Services: Case Management System Jury System Portal - Online case records & services Criminal E-filing Services Public Website Telephone System |
| (b) Publish disaster recovery to cloud (DR2C) roadmap for judicial branch entities (JBEs) that includes design solution templates from Monterey and other participant courts. | In Progress | DR Roadmap to Cloud Assessment Framework & Tools Solutions Analysis & Selection Microsoft Azure Resource Manager(ARM) Templates for infrastructure components Consideration for Case Management System (Odyssey) failover to/from cloud |



7. Disaster Recovery (DR) Initial Pilot and Knowledge Sharing

★ Highlight:

| Key Objectives | Status | Description |
|---|-------------|--|
| (c) Host knowledge-sharing sessions for interested JBEs (including tools to estimate cost for deploying recovery solution using a particular cloud service provider; and Monterey solution case study). | In Progress | Disaster recovery solution recommendation based on Monterey's technology environment assessment to the CIO community in Sep 2019. We had 47 participants for this session. Cloud DR Journey & Lesson Learned (TBD) |
| (d) Evaluate the need for a BCP to fund a pilot group of courts interested in implementing cloud-based DR for critical technology services (see (a)). | Not Started | |
| (e) Coordinate and plan with JCIT regarding operational support, if appropriate. | Not Started | |
| (f) At the completion of these objectives, seek approval of ITAC, JCTC and, if appropriate, the Judicial Council and formally sunset the workstream. | Not Started | |



Challenges



- Incur minimal ongoing costs for cloud footprint (\$\$)
- Limited funding for initial technology costs (\$\$)
- Focus on DR vs Cloud Hosting (\$\$)
- Verify compatibility of cloud infrastructure technologies with current deployments
- Leverage Court's investments in technology resources
- Build internal resource knowledge and competency



Cloud DR Components

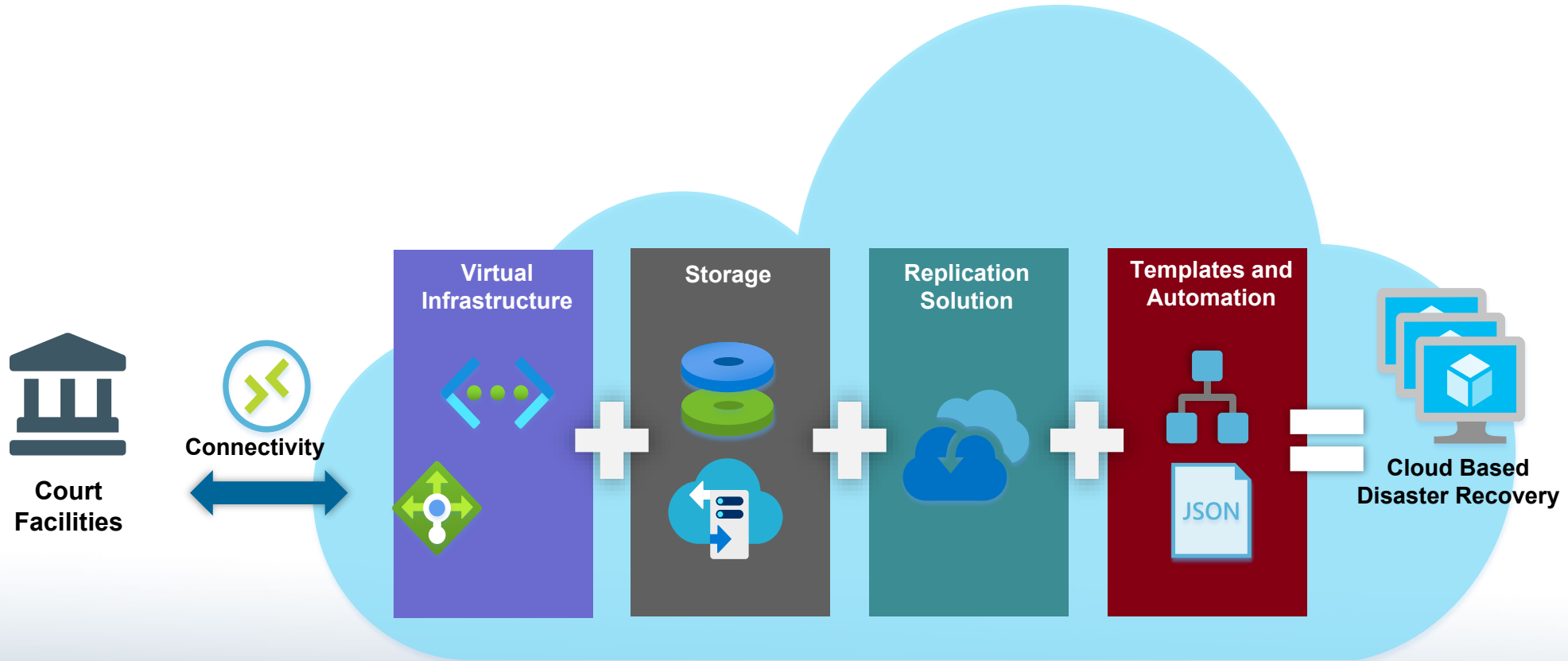

Options



Court Facilities & Connectivity

- Environment Assessment
- Leverage
 - Existing Technologies
 - Skills and Knowledge
- Virtualization Platform
- Coexistence with local DR

Insight: Cloud solutions are constantly evolving.



Insight: Consider Alternatives

- Site to Cloud VPN
- ExpressRoute / Direct Connect
- Data Center Interconnect



Virtual Infrastructure & Storage

- Extend Local Infrastructure to cloud
- Design for Network Security

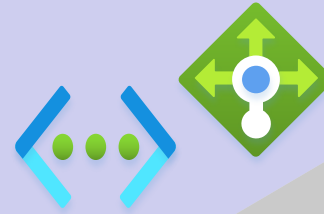

Insight: Inexpensive Storage options for all systems and data

Insight: Consider Need vs Cost for High Availability in the cloud

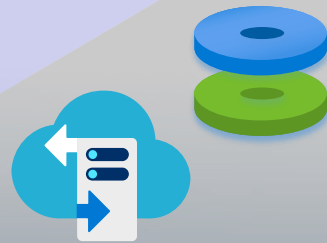

- Cold and Warm tiers
- Failback & Restore



Replication and Automation

- Leverage existing cloud presence
- Recovery Time Objectives
- Simplicity



Insight: Manual triggers for enabling failover

Insight: Existing DR solutions should overlap until new design and path is proven

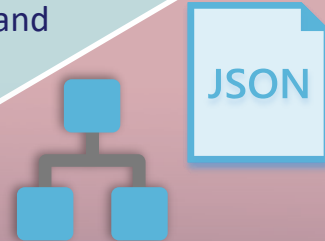

- Run Books specific for each service
- Infrastructure as Code for quick deployments
- Creative Scripting



Pilot Success

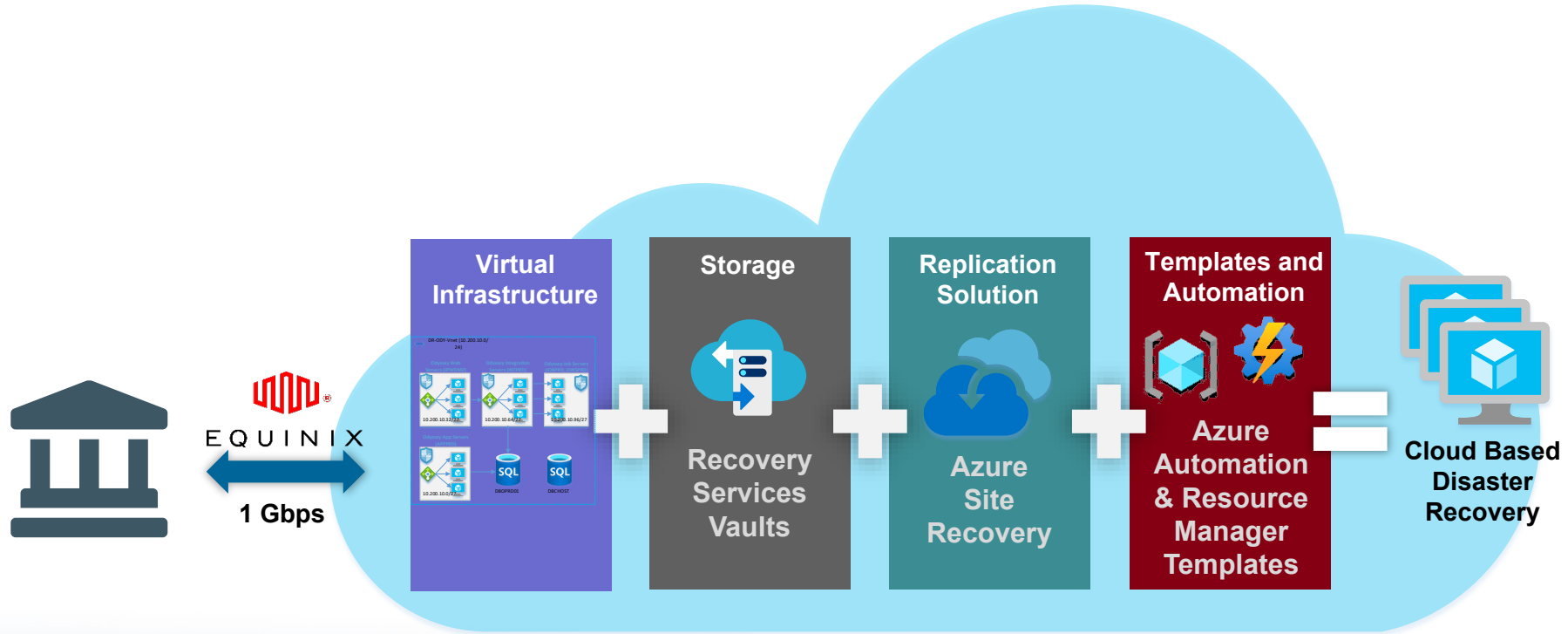

Superior Court of California
County of Monterey



Q&A



Superior Court of California
County of Monterey

Thank You

Brian Damschen, Rick DeNoyer & Paras Gupta



Superior Court of California
County of Monterey

REPORTS

Item 4. Liaison Reports

Reports from members appointed as liaisons to/from other advisory bodies are invited to highlight key accomplishments.

There are no slides for this item.

Adjourn

